

# 405 Series-AD “Alert”

## Particulate Removal and Phase Separation Detection In Alcohol Blended Fuels



### 40510A-AD and 40530A-AD

Detects Phase Separation in  
Ethanol Blended Gasoline

FOR DISPOSAL INFORMATION PLEASE CONTACT YOUR NEAREST EPA OFFICE.

### Benefits

- PetroClear® models 40510A-AD and 40530A-AD are spin-on filters designed to remove particulate, detect and stop flow of phase separation (Ethanol water) in Ethanol blended fuels.
- The “Alert” models 40510A-AD and 40530A-AD are designed to remove particulate and to detect and react to phase separation in Ethanol blended gasoline and slow flow as an indicator to the presence of phase separation. IT WILL NOT SENSE NOR REACT TO WATER IN NON-ALCOHOL BLENDED GASOLINE (NEAT GASOLINE).
- PetroClear® model 40510A-AD filter offers efficient 10 micron (nominal) particulate removal and detects phase separation.
- PetroClear® model 40530A-AD filter offers efficient 30 micron (nominal) particulate removal and detects phase separation.
- Textured paint coating helps ensure a simple, mess-free installation and removal process.
- UL® recognized

**PetroClear® Filters are NOT to be used in Aviation Fuel Applications!**

### Specifications

- The PetroClear® model 40510A-AD utilizes a 10 micron (nominal) cellulose media to remove particulate from Ethanol blended gasoline. Removes particulate 10 microns (nominal) or larger.
- The PetroClear® model 40530A-AD utilizes a 30 micron (nominal) cellulose media to remove particulate from Ethanol blended gasoline. Removes particulate 30 microns (nominal) or larger.
- The “Alert” models 40510A-AD and 40530A-AD are designed to detect and react to phase separation in Ethanol blended gasoline.
- The maximum flow rate for PetroClear® models 40510A-AD and 40530A-AD is 25 gpm (94.6 lpm). Maximum operating pressure is 50 psid (3.4 bar). Collapse pressure is 150 psid (10.3 bar). Maximum operating temperature is 250°F (139°C).
- The chemical center core assembly detects and reacts to phase separation and significantly restricts flow through filters.
- PetroClear® models 40510A-AD and 40530A-AD utilize a standard 1.5"-16 UNF mounting thread ref. (1" flow) required for most spin-on filter adapters used in aftermarket.
- Adapters are available for models 40510A-AD and 40530A-AD in aluminum. These single adapters are available in both 3/4" and 1" NPT or BSP inlet/outlet threads.

**NOTE:** If you experience frequent filter changes, it is recommended that you have fuel samples analyzed to determine the source of contamination, such as water, dirt, rust, bacteria, phase separation, etc.

# 40510A-AD and 40530A-AD Series The “Alert” Detects Phase Separation

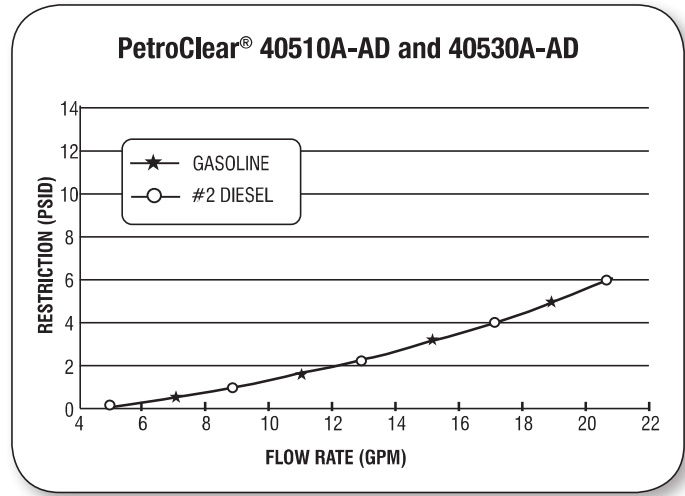
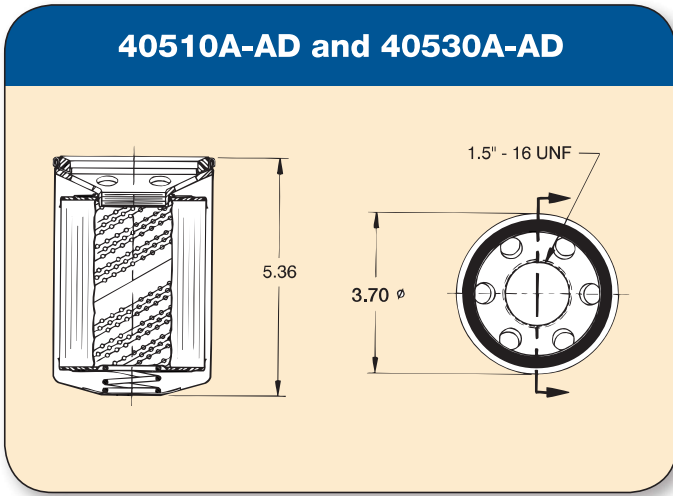

Model	40510A-AD	40530A-AD
Filter Type	Spin-On	Spin-On
Media Type	*Cellulose with Chemical Core	*Cellulose with Chemical Core
Micron Rating	10 Micron (nominal)	30 Micron (nominal)
Diameter	3.70"	3.70"
Height	5.36"	5.36"
Mounting Thread	1.5" – 16 UNF	1.5" – 16 UNF
Flow Rate	25 gpm (94.6 lpm)	25 gpm (94.6 lpm)
Flow	1" flow	1" flow
Shell Thickness	0.020	0.020
Gasket Material	Buna N	Buna N
Collapse (Min.)	150 psid (10.3 bar)	150 psid (10.3 bar)
Burst (Min.)	500 psi (34.5 bar)	500 psi (34.5 bar)
Max. Operating Temp.	250°F (139°C)	250°F (139°C)
Min. Operating Temp.	-20°F (-28.9°C)	-20°F (-28.9°C)

\*Particulate Removing and Chemical Core Detects Phase Separation

## Available Adapters

Part/Model Number	Description
.75 N1.5-16AD	3/4" NPT Inlet/Outlet Ports, 1.5" – 16 UNF (aluminum)
1.0 N1.5-16AD	1" NPT Inlet/Outlet Ports, 1.5" – 16 UNF (aluminum)
.75B1.5-16ADA	3/4" BSP Inlet/Outlet Ports, 1"-16 UNF (aluminum)
1.00B1.5-16ADA	1" BSP Inlet/Outlet Ports, 1"-16 UNF (aluminum)